

기호	변경 사항	날짜	수정	유연
△	변경 내용			

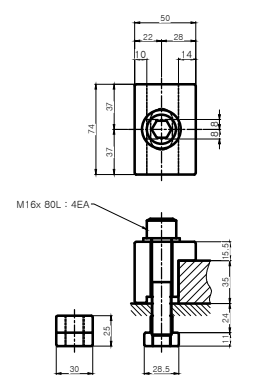

CLAMPING PARTS ACCESSORY 4 PAIR

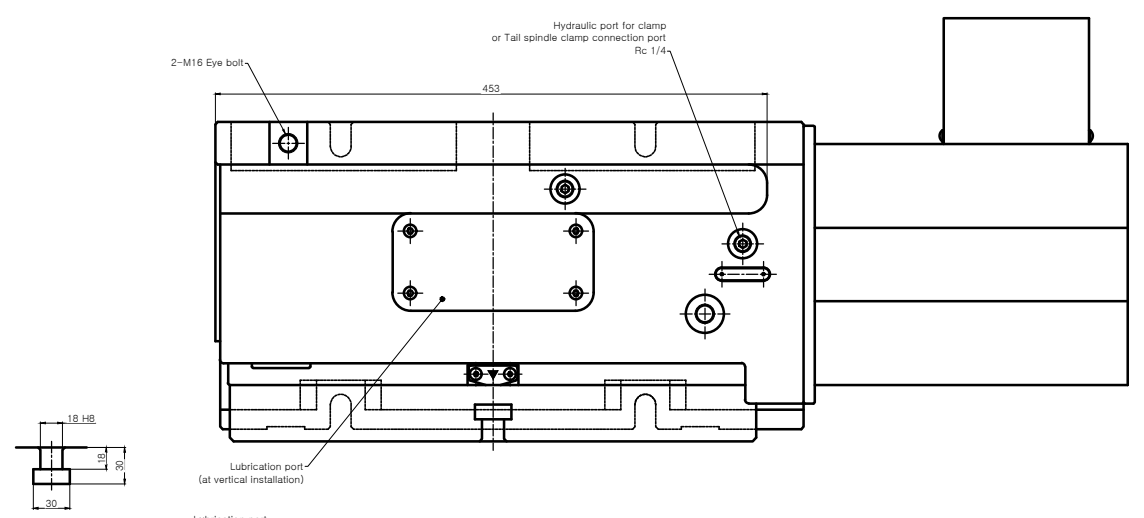
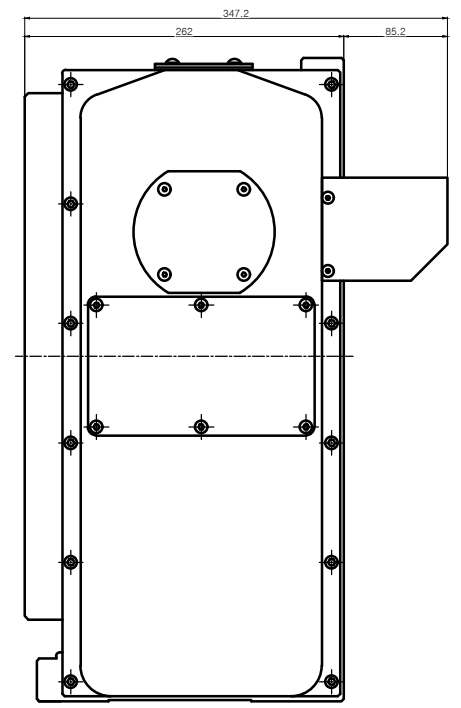
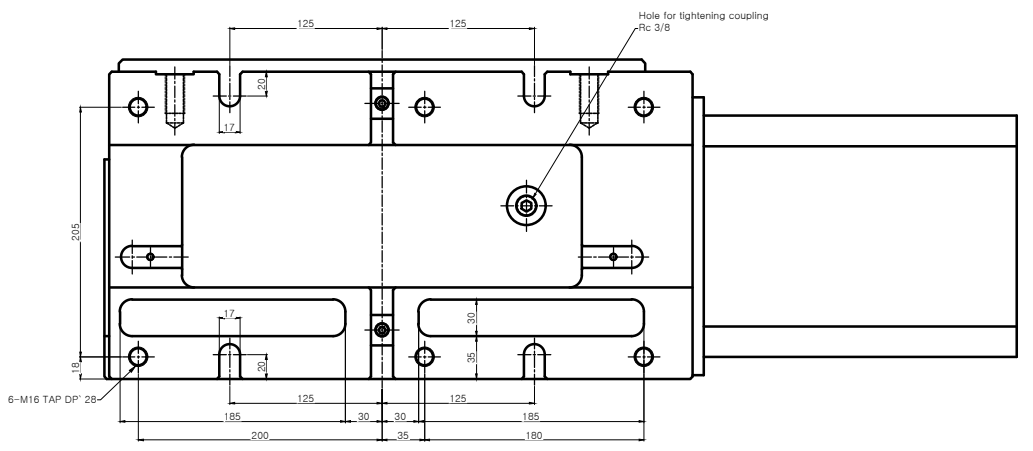
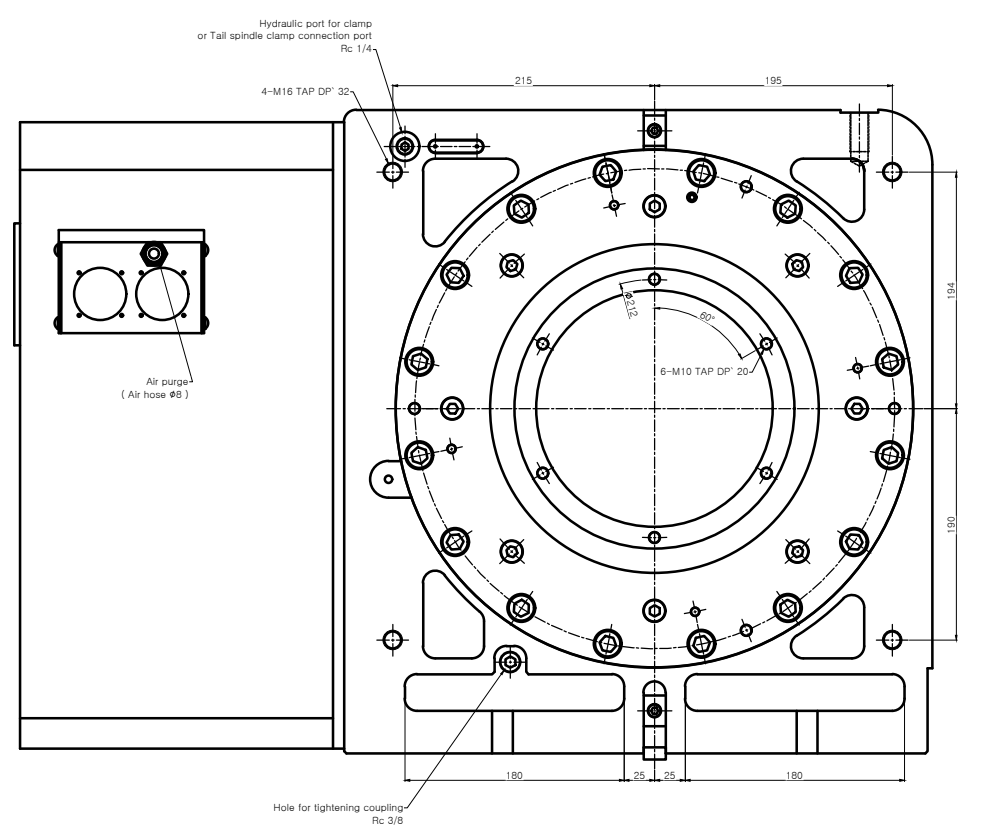
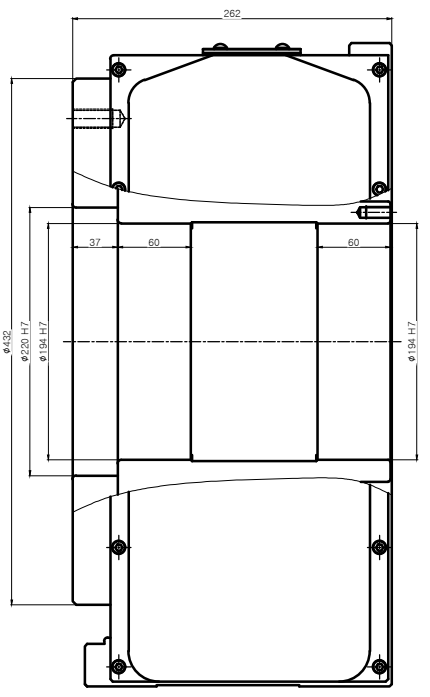
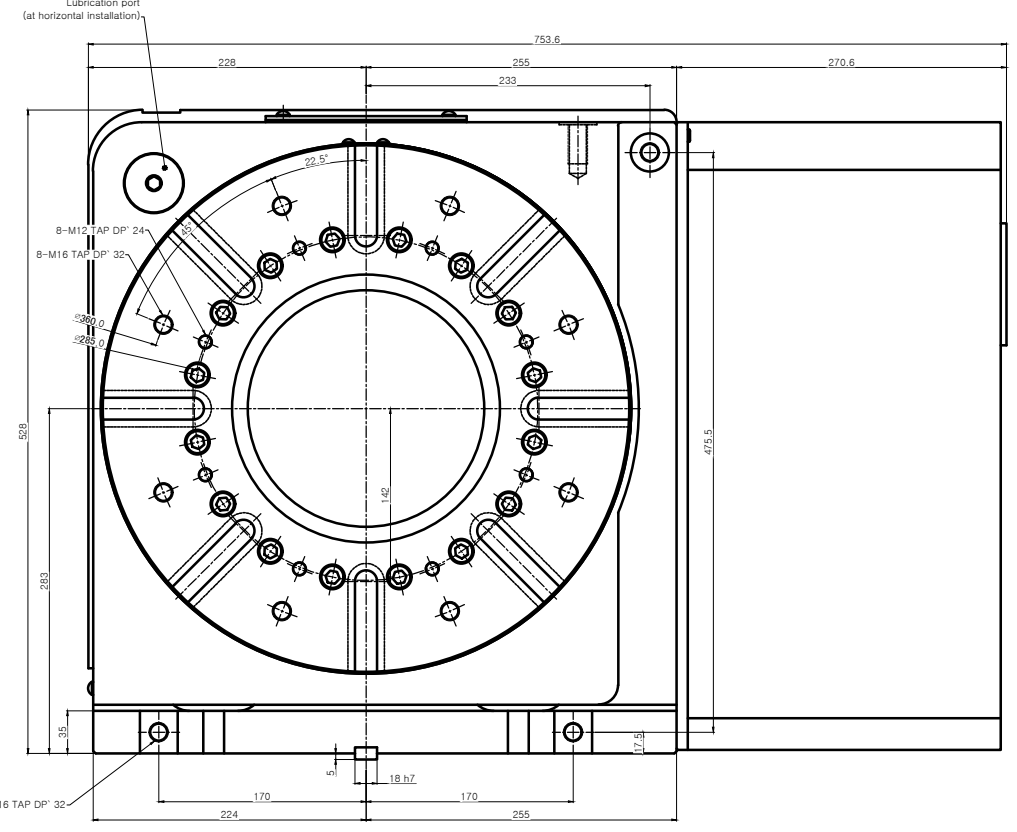
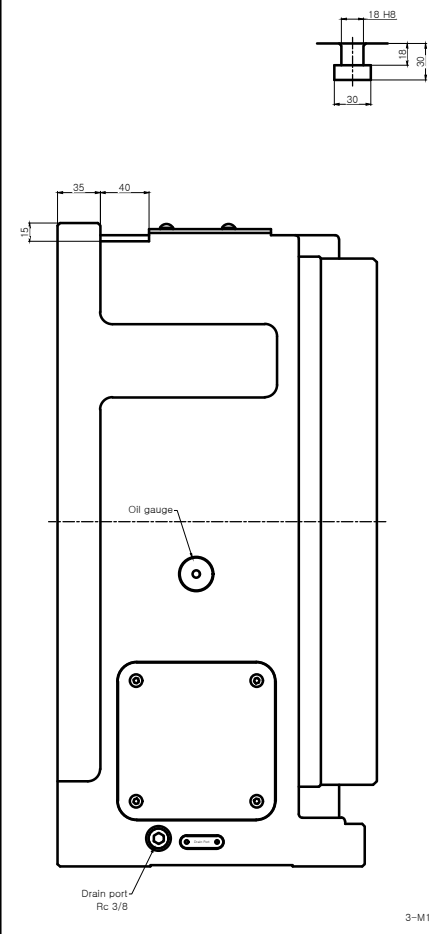

SPECIFICATION	
테이블 직경 Table Diameter	φ432 mm
센터 높이 Center Height	283 mm
테이블 내경 Table Inner Diameter	φ220 H7
관통경 Spindle Through Hole Diameter	φ194 H7
클램프 방식 Clamp Method	Hydraulic 25 ~ 35 kg/cm ²
관성 모멘트 Allowable Work Inertia	10.67 kg·m ²
클램프 토크 Clamp Torque	2500 N·m
회전 속도 Max. Spindle Speed	16.6 min ⁻¹ (MOTOR MAX 2000 min ⁻¹)
기어비 Gear Ratio	1 / 120
무게 Weight	350 kg
기어 오일 Gear Lubrication	ISO VG #220
허용하중	500 kg [HOR.]
ALLOWABLE MASS OF WORK	250 kg [VER.]

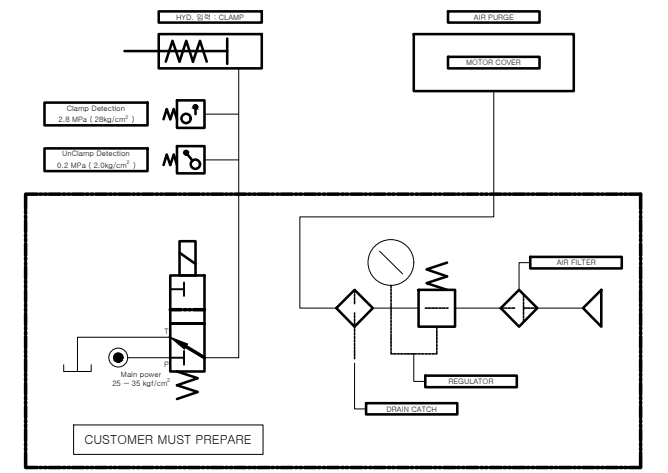
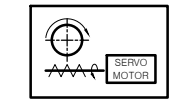

TITLE	Nc Rotary Table	REV	00
DES. NO.	HRD-430Y28-00	USER	-
CODE NO.	-	DEPT	Research & Development
DATE	2016. 01. 14	APPROVED	-
SCALE	1:1	CHECKED	-
		DESIGNED	-

